

AIR VENTS FOR LIQUID SYSTEMS

AVDT Series

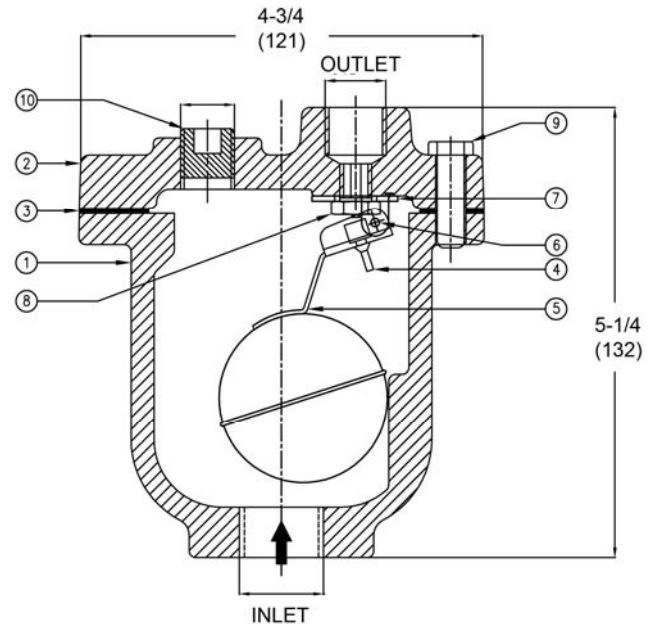

FEATURES

- Improve circulation in liquid systems, with specific gravities greater than 0.7, by eliminating air and non-condensable gases which collect at high points of the system.
- The plugged 1/2" connection in the cover can be outfitted with a full bore ball valve to allow for manual by-pass during system filling.

RATINGS

PMO: (maximum operating pressure): See below chart
 TMO: (maximum operating temperature): 338°F
 (For higher operating temperatures, contact factory)

CONNECTION SIZES

- Inlet: 1/2", 3/4" or 1" (3/4" is standard)
- Outlet: 1/2" only

MATERIALS

Part	Description
(1) Body	Cast Iron – A126, Class B
(2) Cover	Cast Iron – A126, Class B
(3) Gasket	Non Asbestos Fiber
(4) Valve Pin	EPDM
(5) Float Lever Ass'y	Stainless Steel, AISI 304
(6) Bracket Pin	Stainless Steel, AISI 304
(7) Bracket	Stainless Steel, AISI 304
(8) Valve Seat	Stainless Steel, AISI 304
(9) Bolts	Carbon Steel
(10) Plug (1/2")	Carbon Steel

AIR CAPACITY (Discharge to atmosphere) IN SCFM

Model	Orifice		25 psi	50 psi	75 psi	100 psi	125 psi	150 psi	200 psi	300 psi	Weight	
	mm	in	172 kPa	345 kPa	517 kPa	690 kPa	862 kPa	1034 kPa	1379 kPa	2068 kPa	kg	lbs
AVDT-150	1.6	1/16	1.6	2.7	3.7	4.8	5.9	6.9	—	—	2.5	5.5
AVDT-300	1.19	3/64	1.1	1.8	2.5	3.2	3.9	4.6	6.0	7.4	2.7	6.0

Colton has a policy of continuous product research and improvement and reserves the right to change design and specifications without notice.



Tel: 1-888-300-9155 Fax: 1-888-300-9160 www.COLTONIND.com info@coltonind.com