

# THERMODYNAMIC STEAM TRAPS

## SV-1 Series

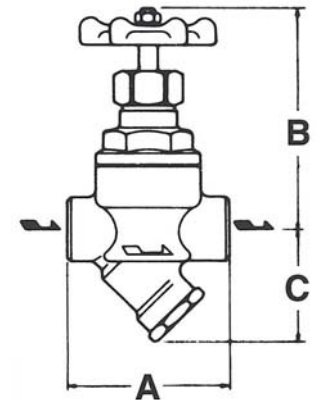
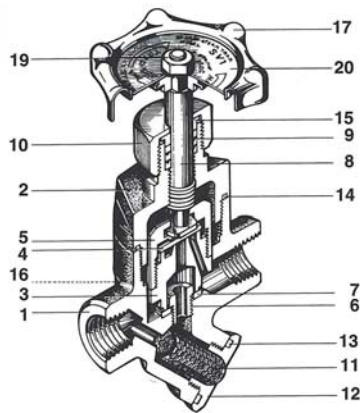

### FEATURES

- Integral strainer
- Integral by-pass valve

### RATINGS

PMO: (maximum operating pressure): 5 to 225 psi  
 PMA: (maximum allowable pressure): 225 psi  
 TMO: (maximum operating temperature): 428°F

### MATERIALS

Part	Description
(1) Body	Forged Carbon Steel
(2) Cover	Ductile Iron
(3) Seat	13 cr. Stainless Steel
(4) Disc	13 cr. Stainless Steel
(5) Cap	13 cr. Stainless Steel
(6) Bushing	Brass

Part	Description
(7) Valve Seat	PTFE
(8) Stem	Stainless Steel
(9) Gland Packing	PTFE
(10) Nut	Brass
(11) Screen	Stainless Steel
(12) Plug	Carbon Steel
(13) Gasket	PTFE
(14) Gasket	PTFE
(15) Gland Bushing	PTFE
(16) Pin	Stainless Steel
(17) Handle	Steel
(19) Nut	Carbon Steel
(20) Name Plate	Name Plate

### DIMENSIONS AND WEIGHTS

Size		A		B		C		Weight	
mm	in	mm	in	mm	in	mm	in	kg	lbs
15	1/2	78	3-1/16	41	1-5/8	95	3-3/4	0.94	2
20	3/4	90	3-9/16	43	1-11/16	110	4-1/3	1.10	2.5
25	1	95	3-3/4	52	2-3/64	124	4-7/8	1.60	3.5

### CAPACITIES IN POUNDS & KILOGRAMS PER HOUR OF CONDENSATE

	69	10	173	25	345	50	690	100	1034	150	1379	200	1551	225
	kpa	psi	kpa	psi	kpa	psi	kpa	psi	kpa	psi	kpa	psi	kpa	psi
Trap Capacity	68	150	100	220	159	350	222	490	272	600	318	700	350	770
Blow-Off Capacity	500	1100	681	1500	908	2000	1135	2500	1272	2800	1408	3100	1499	3300

Colton has a policy of continuous product research and improvement and reserves the right to change design and specifications without notice.



Tel: 1-888-300-9155 Fax: 1-888-300-9160 www.COLTONIND.com info@coltonind.com